

# GXS DRY SCREW VACUUM PUMPS

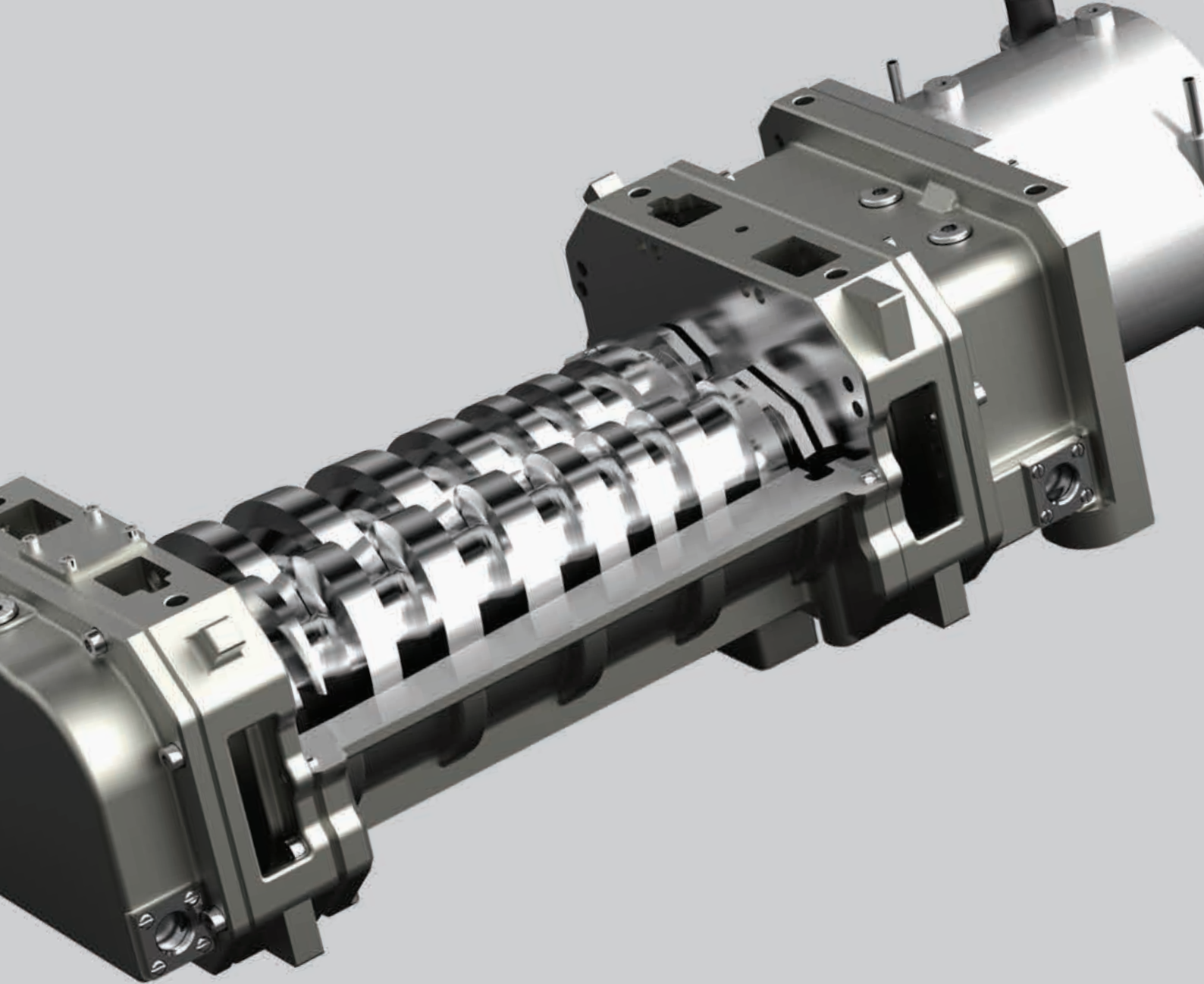



## EDWARDS THE PARTNER OF CHOICE

**Edwards is a world leader in the design, technology and manufacture of vacuum pumps with over 95 years' history and more than 75 years' manufacturing experience.**

Edwards believes in delivering results that bring value to our customers by using our breadth of industry experience to identify and apply solutions to your problems. Using the most innovative and up-to-date modelling techniques, we can optimise the pumping configuration for customers to provide a system design giving the maximum performance in the most reliable and cost-effective way.

# GXS DRY SCREW PUMPS AND COMBINATIONS

Our new GXS dry pumps take vacuum performance to the next level. With unique screw technology and world leading high efficiency drives, enabling advanced temperature control and long service intervals, you are guaranteed best-in-class pumping speeds and low running costs for many years to come.

## **Fast** – *Reduced pump down times with ultimate vacuum of $5 \times 10^{-4}$ mbar*

- **Increased productivity:** faster process
- **Improved product quality:** better ultimate vacuum

## **Robust** – *Reliable operation even in harsh industrial applications*

- **Low maintenance cost:** no unplanned down-time
- **Increased productivity:** longer intervals between service

## **Intelligent** – *On-board controller with extensive communication and automated control capabilities*

- **Reduced installation costs:** easy integration with other systems
- **Safe operation, consistent output:** automated control of your process

## **Economical** – *Affordable capital investment and low cost of ownership*

- **Substantial savings:** low utilities and energy usage costs
- **Save on space:** small footprint

## **Environmental** – *Smooth, quiet running with low power and utilities consumption*

- **Small carbon footprint:** low power and utilities usage
- **Easy on environment:** no contaminated or dirty disposable oil

# GXS innovative screw technology

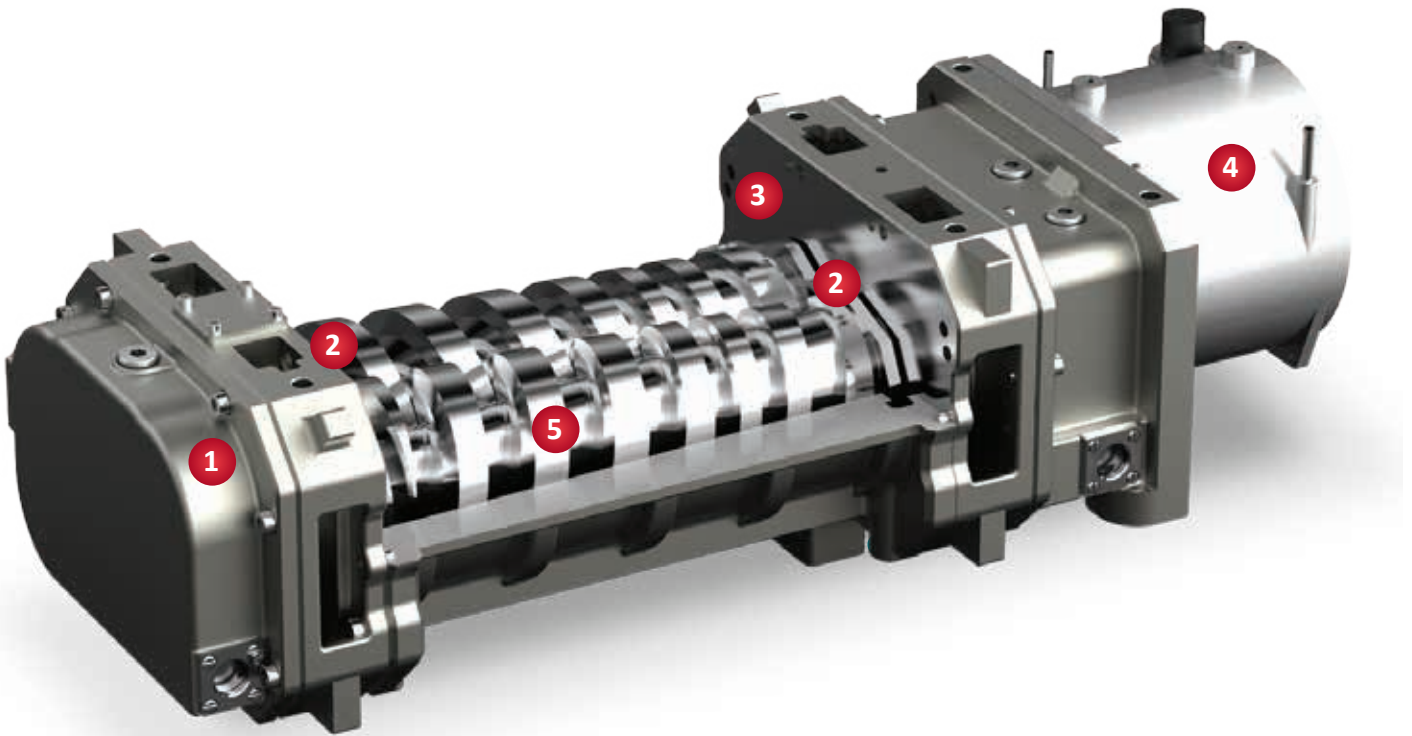

1

## Double ended shaft support

- Non-cantilever design provides secure rotor support for extremely low vibration and superior starting reliability, especially on harsh processes
- Superior liquid and powder handling. Tests demonstrate a five litre water slug and one kilogram fine powder slug handling capability

2

## Bearing and lubrication

- Oil lubricated gears eliminate grease and the need for periodic maintenance
- Uses advanced quality bearings and special purpose oil with low vapour pressure for application compatibility and greatly improved life

3

## Advanced shaft sealing technology

- Non-contacting long-life seals with integral oil blocking labyrinth seal provides for highly effective sealing
- Combined with a six litre per minute seal purge the gearbox is protected from contamination and the vacuum space is kept free of oil

## Fully enabled intelligent on-board control panel

- Running mode and fault status indicator with soft button control
- True “plug and pump” capability for immediate operation
- Intelligently programmed with automatic start/stop routines, power saving, green mode AUC and self cleaning options
- Remote control and monitoring functionality through Ethernet and serial connectors (including Profibus, simple text control protocol, and discrete hard-wired I/O options)
- Optional Pump Display Terminal (PDT) for improved diagnostic and configuration capacity



# GXS booster

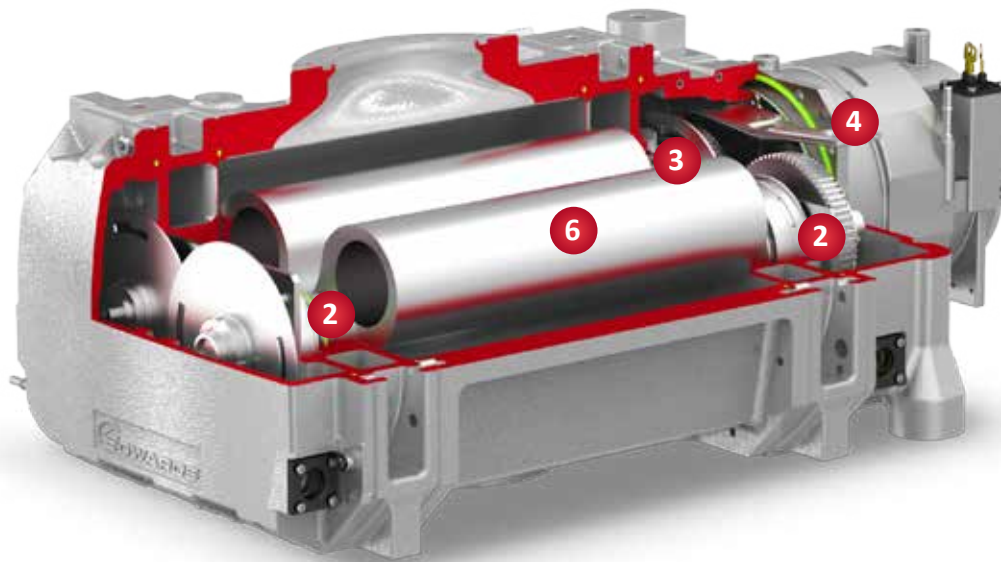

4

## World leading motor and drive technology

- Extremely high efficiency motors with electronic drives deliver maximum torque performance for difficult processes
- Hermetically sealed motor eliminates oil leaks and improves pump reliability
- Water-cooled motors and drives provide for improved reliability and long life to reduce service costs

5

## Advanced pumping mechanism design

- Enhanced screw-type rotor design results in smooth, gradual compression along the length of the rotor for improved thermal control and optimised pumping at all inlet pressures
- Integrated heat management and unique rotor and stator design features provide argon gas pumping capability at full concentration
- Advanced machining techniques and design features eliminate the need for rotor coatings while maintaining superb ultimate vacuum performance
- Improved manufacturing technology and design contributes to low vibration and extremely quiet running without a silencer

6

## Roots booster mechanism

- High efficiency vacuum booster design
- Optimised for maximum performance with automatic thermal management



## Applications

### Metallurgy

- Vacuum Brazing
- E-beam welding
- Nitro carburising
- Low pressure nitriding
- Low pressure carburising
- Carbon vapour impregnation
- Sintering
- Metal injection moulding
- Precision investment casting
- Electroslag remelting
- Vacuum induction melting
- Vacuum arc refining
- Steel degassing

### Coating

- Roll web coating
- Hard coating (CVD/DLC)
- Surface activation
- Plasma spray
- Glass coating

### Drying

- Freeze drying
- Bushing filling
- Transformer drying
- Pipeline drying
- Capacitor drying
- Lithium-Ion battery drying

### Plasma processes

- Plasma welding
- Plasma nitriding

### Solar

- Silicon crystal-pulling
- PV lamination

### LED manufacture

### Vacuum chamber evacuation

- Space simulation chambers
- Gas recovery/circulation
- Load lock chambers

# Customised solutions for your application

Whether you require a single pump, pump and booster combination or complete vacuum system, we have a range of pumps designed to provide optimal performance in a wide range of applications.

Following are some typical applications where GXS is used. There are several other applications where GXS is suitable. For detailed advice and availability, please consult one of our application engineers.

Application	GXS Pump type					Recommended Accessories	
	LIGHT DUTY Shaft Seal Purge only	MEDIUM DUTY Shaft Seal Purge plus adjustable Gas Ballast. Inlet purge on start up and shut down	MEDIUM DUTY 450 / 750 As standard Medium duty + option of additional Gas Ballast	MEDIUM DUTY + As Medium Duty plus HIGH FLOW PURGE ONLY at shutdown	MEDIUM DUTY + High Flow Purge AND SOLVENT FLUSH at shutdown	INLET FILTER Metal mesh type	SILENCER Cleanable and drainable type
Annealing	✓						
CVI carbon vapour impregnation		✓	✓		✓	✓	✓
EB welding		✓				✓	
Gas quenching	✓						
LPC low pressure carburising		✓	✓		✓*	✓	✓
LPN low press. Nitriding	✓						
Sintering (Metal Injection Molding) & debinding		✓	✓		✓**		
Oil quenching		✓				✓	
PIC precision investment casting & fast cycling		✓		✓		✓	
Plasma nitriding (PN)	✓						
Tempering	✓						
Vacuum brazing		✓			✓	✓	
VAR		✓	✓	✓		✓	
VIM		✓	✓	✓		✓	

\* use MD+ for LPC with propane

\*\* use MD+ for waxy binders

# Technical data

		Unit	GXS160	GXS160/1750	GXS250	GXS250/2600
Peak Pumping Speed		m <sup>3</sup> /hr (cfm)	160 (94)	1200 (706)	250 (147)	1900 (1118)
Ultimate Pressure (without purge)		mbar (Torr)	7x10 <sup>-3</sup> (5.3x10 <sup>-3</sup> )	7x10 <sup>-4</sup> (5.3x10 <sup>-4</sup> )	4x10 <sup>-3</sup> (3.0x10 <sup>-3</sup> )	5x10 <sup>-4</sup> (3.8x10 <sup>-4</sup> )
Full Load Power	@ ultimate pressure	kW (hp)	3.8 (5.1)	5.1 (6.8)	4.0 (5.4)	5.3 (7.1)
	@ peak pumping load	kW (hp)	5.0 (6.7)	7.4 (9.9)	9.0 (12.1)	9.7 (13.0)
Electrical	Supply options	High volt	380-460V 3Ø 50/60Hz		380-460V 3Ø 50/60Hz	
		Low volt	200-230V 3Ø 50/60Hz		200-230V 3Ø 50/60Hz	
	Connection	High volt	Harting Han K 4/4-F		Harting Han K 4/4-F	
		Low volt				
Vacuum Couplings	Inlet		ISO63	ISO100	ISO63	ISO160
	Exhaust		NW40		NW40	
Cooling Water	Supply pressure (max)	bar (psig)	6.9 (100)		6.9 (100)	
	DP across pump (min)	bar (psig)	1.0 (14.7)		1.0 (14.7)	
	Flow @ min DP	l/min (gal/min)	4.0 (1.1)	7.0 (1.9)	4.0 (1.1)	7.0 (1.9)
	Temperature	°C (°F)	5-40 (41-104) All variants		5-40 (41-104) All variants	
	Connection		3/8" BSP Male (G 3/8")		3/8" BSP Male (G 3/8")	
Purge Gas*	Pressure	bar (psig)	2.5-6.9 (36-100)		2.5-6.9 (36-100)	
	Light Duty	sl/min	12		12	
	Medium Duty	sl/min	18-52		18-52	
	Connection		Swagelok® Ø ¼" tube with olive		Swagelok® Ø ¼" tube with olive	
High Flow Purge/ Solvent Flush	Supply pressure	bar (psig)	2.5-6.9 (36-100)		2.5-6.9 (36-100)	
	Control valve connection		Swagelok® Ø 3/8" tube with olive		Swagelok® Ø 3/8" tube with olive	
	Filter connection		½" NPT Male		½" NPT Male	
	Solvent connection		3/8" BSP Male (G 3/8")		3/8" BSP Male (G 3/8")	
Mass		Kg (lbs)	305 (672)	475 (1047)	305 (672)	515 (1035)
Noise (with suitable exhaust pipe)		dB(A)	<64		<64	
Operating Temperature		°C (°F)	5-40 (41-104)		5-40 (41-104)	
Exhaust Back Pressure (MAX)		mbar (psia)	1400 (20)		1400 (20)	
System IP rating	Standard		21D		21D	
Lubrication	Type		PFPE Drynert® 25/6		PFPE Drynert® 25/6	
	Volume	l (gal)	0.7 (0.2)	1.4 (0.4)	0.7 (0.2)	1.4 (0.4)
Monitoring & Control	Standard	Control	Front panel "Dashboard" Serial - RS232		Front panel "Dashboard" Serial - RS232	
		Monitoring	Ethernet Webserver		Ethernet Webserver	
	Option	Control	Parallel - MCM MicroTIM		Parallel - MCM MicroTIM	
		Control & Monitoring	Profibus DP Pump Display Terminal (PDT)		Profibus DP Pump Display Terminal (PDT)	
		Monitoring	FabWorks®		FabWorks®	
*Pump combinations	Light duty		Shaft Seal Purge only		Shaft Seal Purge only	
	Medium duty		Shaft Seal Purge, High Vac Purge, Inlet Purge, variable Gas Ballast & Exhaust Purge (with Exhaust Pressure Sensor)		Shaft Seal Purge, High Vac Purge, Inlet Purge, variable Gas Ballast & Exhaust Purge (with Exhaust Pressure Sensor)	
	Medium duty +		As Medium duty, plus High Flow Purge / Solvent Flush		As Medium duty, plus High Flow Purge / Solvent Flush	

\* Purge Gas information, Light duty: shaft seal purge only, Medium duty: Shaft seal purge, inlet purge, variable gas ballast & exhaust purge (with exhaust pressure sensor), Medium duty plus: As Medium duty, plus High Flow Purge/Solvent Flush

GXS450	GXS450/2600	GXS450/4200	GXS750	GXS750/2600	GXS750/4200
450 (265)	2200 (1295)	3026 (1781)	740 (436)	2300 (1354)	3450 (2031)
$5 \times 10^{-3}$ (3.8x10 <sup>-3</sup> )	$5 \times 10^{-4}$ (3.8x10 <sup>-4</sup> )		$3 \times 10^{-3}$ (2.3x10 <sup>-3</sup> )	$5 \times 10^{-4}$ (3.8x10 <sup>-4</sup> )	
7.2 (9.6)	8.8 (11.8)	9.4 (12.6)	10.0 (13.4)	11.1 (14.9)	11.5 (15.4)
17.3 (23.2)	20.0 (26.8)	21.1 (28.3)	37.0 (49.6)	40.0 (53.6)	40.0 (53.6)
380-460V 3Ø 50/60Hz			380-460V 3Ø 50/60Hz		
200-230V 3Ø 50/60Hz			200-230V 3Ø 50/60Hz		
Harting Han K 4/4-F		Harting Han 100A-F		Harting Han 100A-F	
				Harting Han 200A-F	
ISO100		ISO160		ISO100	
		NW50		NW50	
		6.9 (100)		6.9 (100)	
1 (15)		1 (15)		0.75 (11)	
10 (2.6)		12 (3.2)		15 (4)	
5-40 (41-104) All variants			5-40 (41-104) High Volt variants		
			5-30 (41-86) Low Volt variants		
1/2" BSP Male (G 1/2")			1/2" BSP Male (G 1/2")		
2.5-6.9 (36-100)			2.5-6.9 (36-100)		
12			12		
18-146			18-146		
Swagelok® Ø ¼" tube with olive			Swagelok® Ø ¼" tube with olive		
2.5-6.9 (36-100)			2.5-6.9 (36-100)		
Swagelok® Ø 3/8" tube with olive			Swagelok® Ø 3/8" tube with olive		
½" NPT Female			½" NPT Female		
3/8" BSP Male (G 3/8")			3/8" BSP Male (G 3/8")		
640 (1411)	860 (1996)	868 (1914)	640 (1411)	908 (2002)	953 (2101)
<64			<70		
5-40 (41-104)			5-40 (41-104)		
1400 (20)			1400 (20)		
21D			21D		
PFPE Drynert® 25/6			PFPE Drynert® 25/6		
1.8 (0.5)	2.5 (0.7)	3.6 (1.0)	2.4 (0.6)	3.1 (0.8)	4.2 (1.1)
Front panel "Dashboard" Serial - RS232			Front panel "Dashboard" Serial - RS232		
Ethernet Webserver			Ethernet Webserver		
Parallel - MCM MicroTIM			Parallel - MCM MicroTIM		
Profibus DP Pump Display Terminal (PDT)			Profibus DP Pump Display Terminal (PDT)		
FabWorks®			FabWorks®		
Shaft Seal Purge & High Vac Purge only			Shaft Seal Purge & High Vac Purge only		
Shaft Seal Purge, High Vac Purge, Inlet Purge, variable Gas Ballast & Exhaust Purge (with Exhaust Pressure Sensor)			Shaft Seal Purge, High Vac Purge, Inlet Purge, variable Gas Ballast & Exhaust Purge (with Exhaust Pressure Sensor)		
As Medium duty, plus High Flow Purge / Solvent Flush			As Medium duty, plus High Flow Purge / Solvent Flush		

# Dimensions

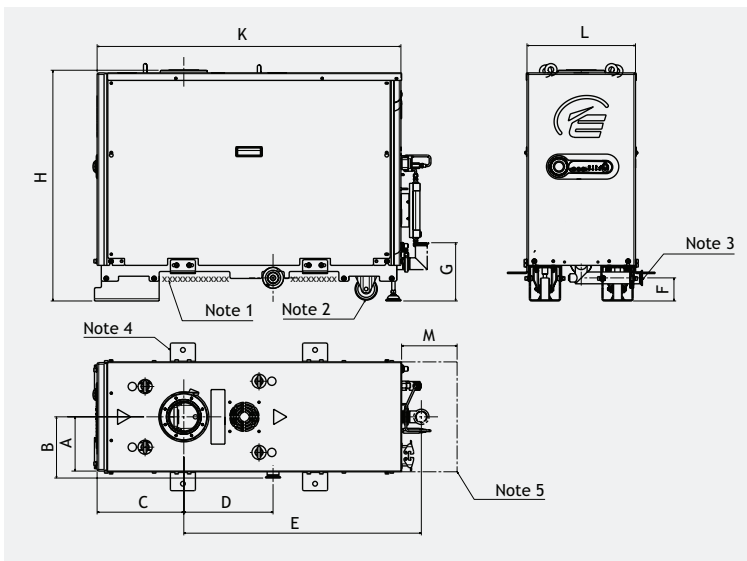
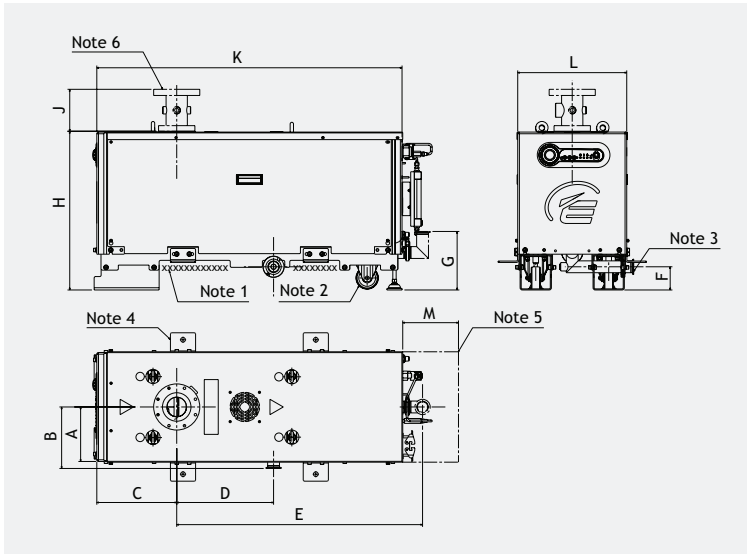

## Notes:

- xxxxxx indicate forklift/pallet truck access points.
- Pumps are available either with skids (side-exit exhaust) or castors (rear-exit exhaust). Both options are shown for clarity.
- Pumps supplied with side or rear exhaust only; both options shown in views. The side exhaust outlet direction is customer adjustable.
- Earthquake restraints are provided only for pumps with castors.
- Minimum required service area for access to the rear panel connections.
- The High-Flow Purge / Solvent Flush accessory is located outside of the pump enclosure for dry pump only. It is inside the enclosure for pump/booster combinations.

	A	B	C	D	E	F	G	H	J	K	L	M
GXS160			285.9 (11.26)	346.5 (13.64)	879.5 (34.63)			568 (22.36)	150 (5.9)			
GXS250	195 (7.68)	220 (8.66)					209.4 (8.24)			1092 (42.99)	390 (15.35)	250 (9.84)
GXS160/1750			311.6 (12.27)	320.8 (12.63)	853.8 (33.61)			829.5 (32.66)				
GXS250/2600												
GXS450			394 (15.51)	300 (11.81)	871.6 (34.31)					1186 (46.69)		
GXS750			576.4 (22.69)	413 (16.23)	1133.6 (44.63)	83 (3.27)		717 (28.23)	150 (5.9)	1622 (63.86)		
GXS450/2600	258.5 (10.18)	283.5 (11.16)					261.4 (10.29)				517 (20.35)	250 (9.84)
GXS450/4200			361.8 (14.24)		903.8 (35.58)					1186 (46.69)		
GXS750/2600				332.3 (13.08)				1030.5 (40.57)				
GXS750/4200			657.2 (25.87)		1052.8 (41.45)					1622 (63.86)		

Key pump dimensions: mm (ins)

# Performance curves

## Pumping speed curves for GXS160 & GXS250

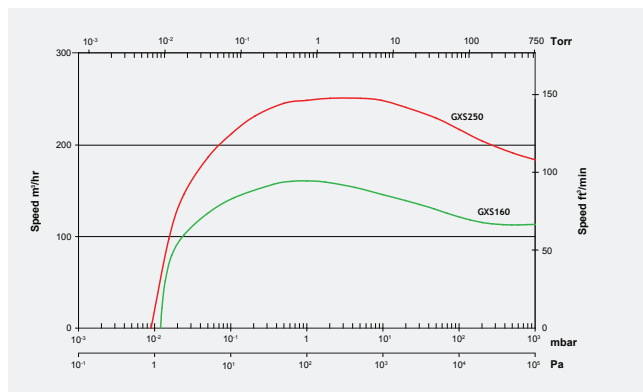

## Pumping speed curves for GXS160/1750 & GXS250/2600

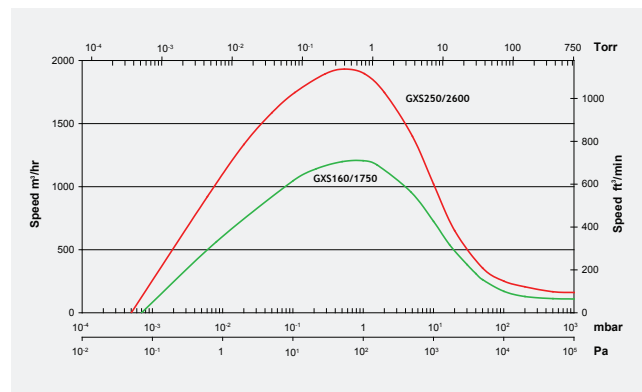

## Pumping speed curves for GXS450

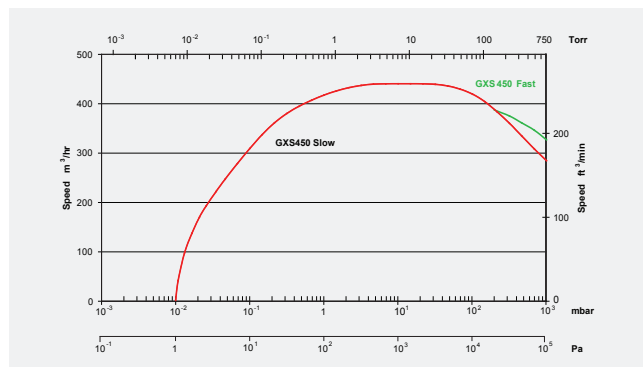

## Pumping speed curves for GXS450/2600 & GXS450/4200

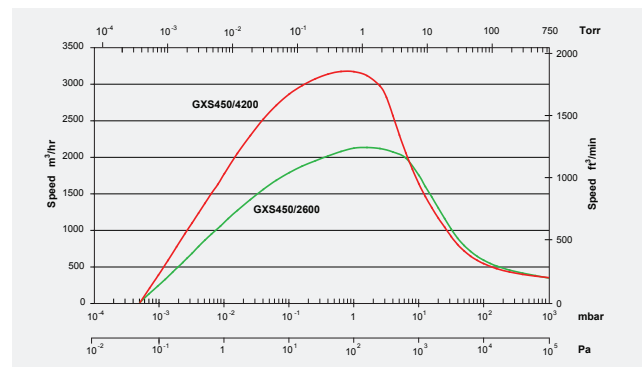

## Pumping speed curves for GXS750

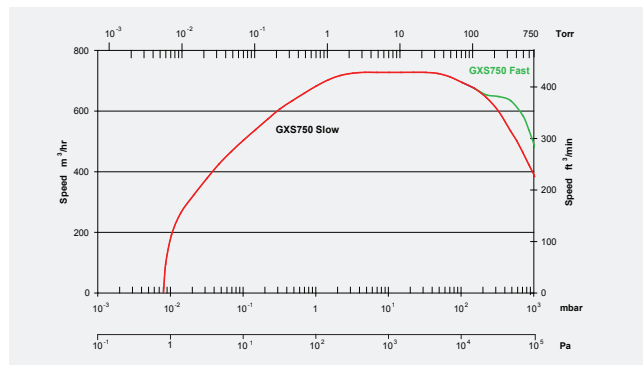

## Pumping speed curves for GXS750/2600 & GXS750/4200

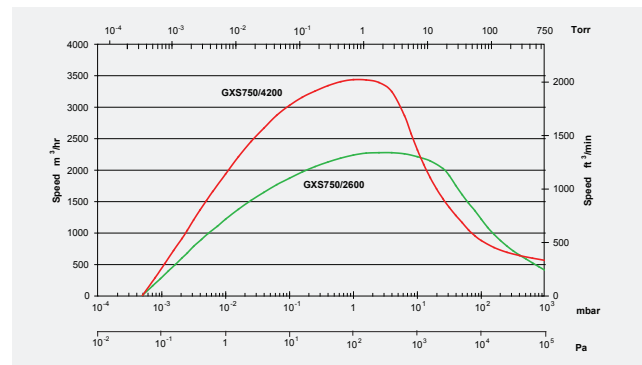

NOTE: Performance curves displayed are with purge.



## Accessories

There are a range of accessories available with the GXS to suit a variety of applications. These provide reduced engineering and systemisation resulting in low cost of ownership. All accessories are fully integrated with GXS to provide an efficient and safe system.

### Inlet and exhaust accessories

Inlet and exhaust accessories have been especially designed to match the pumping capacities of the GXS range and optimise performance.

- Foreline spool adapters for mounting instrumentation
- Fully integrated Inlet isolation valves
- Inlet filter housing with polyester or stainless steel elements
- Exhaust silencers with cleanable drainable options
- Exhaust check valves

### Control and monitoring accessories

We have designed a range of control and monitoring accessories specifically for the GXS range to enable complete integration into your control systems.

- Hand held terminals
- Profibus / Digital interface modules
- Water / N<sub>2</sub> flow monitoring kits
- Pressure and temperature transmitters
- Visual pressure and temperature gauges

## Inlet Vacuum Filters

The GXS range of pumps all have excellent powder handling capabilities and under fault conditions they will succeed where other dry pumps fail. However dry vacuum pumps aren't designed to continuously pump solid material so on certain applications an inlet filter would dramatically extend the time between services.

## Specifications

Helium leak tested to  $1 \times 10^{-6}$  mbar/l/sec

- Polyester Elements: >99% efficient to  $5 \mu\text{m}$
- Rugged carbon steel construction
- Large dirt holding capacity

## Options

- Stainless steel housing construction
- Stainless steel mesh filter elements

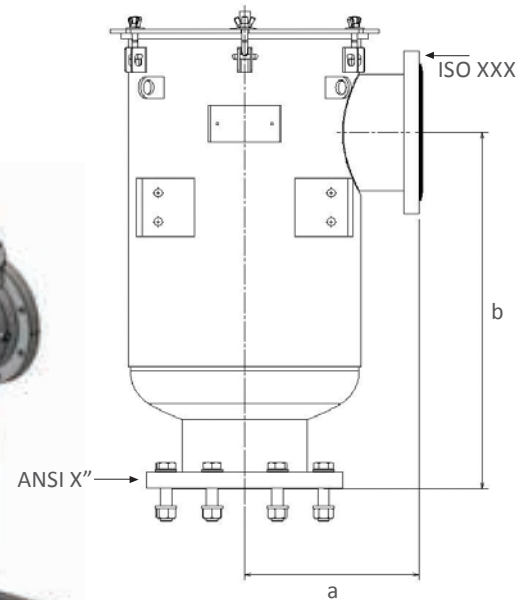

Pump Type	Recommended Inlet Filter			Inlet Connection ISO Flange	Outlet Connection ANSI Flange	Dimensions	
	Size	CS Part No.	SS Part No.			a	b
All Pump only and 1750 booster combination	4"	M58808005	M58808137	100	4"	254 (10.0)	251 (9.9)
All 2600 booster combinations	6"	M5882805	M58828137	160	6"	305 (12.0)	521 (20.5)
All 4200 booster combinations	8"	M59848005	M59848137	200	8"	305 (12.0)	622 (24.5)

Element Construction	Replacement Filter Element			Particle Size	Efficiency
	4" Part Number	6" Part Number	8" Part Number		
Polyester / Galvanised	A22304363	A22304367	A22304371	5 micron	>99%
Polyester / Stainless Steel	A22304365	A22304369	A22304373	5 micron	>99%
Stainless Mesh	A22304366	A22304370	A22304374	300 micron	90%

## Automatic Inlet Isolation Valves

The automatic GXS isolation valve is designed to fully integrate into the GXS control system to protect the pump and your process.

The valve will close in the event of an alarm or power failure and will isolate the process when in green mode for energy saving between production batches.

### Specifications

- Stainless steel and EPDM construction for corrosion resistance
- High CV, low pressure drop
- Pneumatic actuation with spring return
- Fully integrated to enable 'green' energy saving mode
- Protects pump by not allowing it to go online until it is up to operating temperature

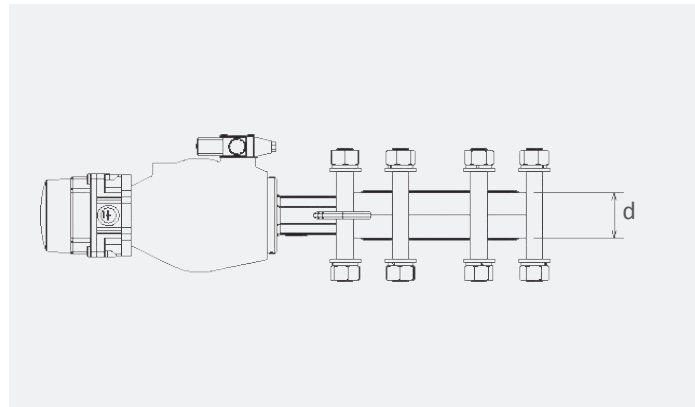
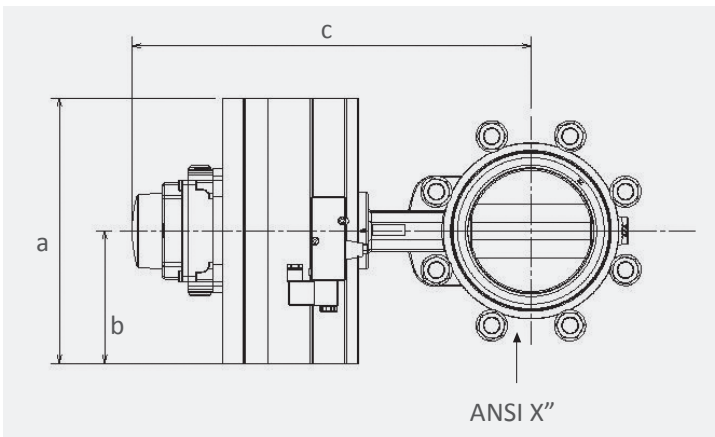

Pump Type	Recommended Silencer		Connection ANSI Flange Pattern	Dimensions mm (inches)			
	Size	Part No.		a	b	c	d
All Pump only and 1750 booster combination	4"	M588808004	4"	302 (11.9)	152.5 (6.0)	424.4 (16.7)	51.2 (2.0)
All 2600 booster combinations	6"	M58828004	6"	313 (12.3)	156.5 (6.2)	470 (18.5)	55.3 (2.2)
All 4200 booster combinations	8"	M59848004	8"	452 (17.8)	228 (8.9)	595 (23.4)	59.3 (2.3)

## Harsh Duty Exhaust Silencers

The GXS already has 'best in class' decibel ratings but in some tricky installations noise attenuation is essential. A range of silencers have a bespoke design tailored to the pumping capacity of the GXS high speed screw pumps.

### Specifications

- Painted carbon steel or stainless steel construction
- Drainable and cleanable design for condensable / harsh processes
- Greater than 15 dBA noise reduction on some installations

### Options

- Drain valve assembly
- Mounting kits

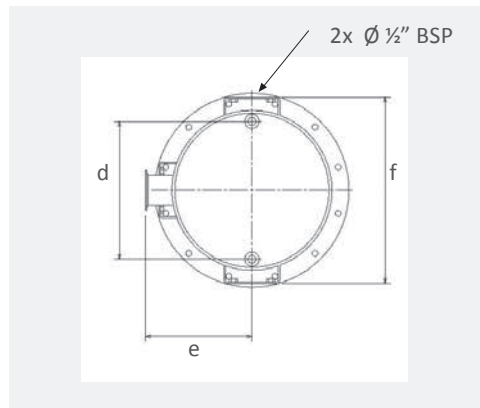
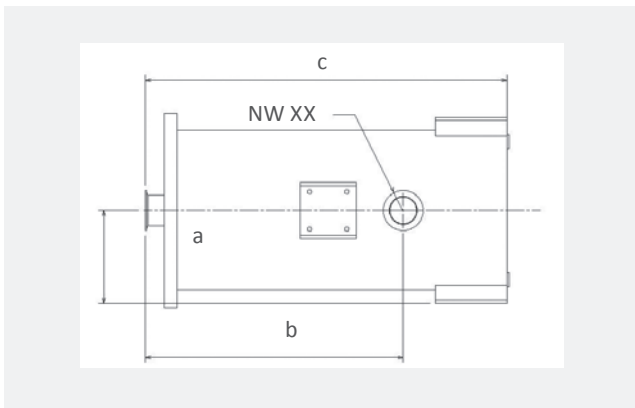

Pump Type	Recommended Silencer		Inlet and exhaust connection type	Dimensions mm (inches)					
	Carbon Steel	Stainless Steel		a	b	c	d	e	f
All GXS 160 and GXS 250	M58808161	M58808162	NW40	105 (4.1)	333 (13.1)	525 (20.7)	132 (5.2)	105 (4.1)	210 (8.3)
All GXS 450 and GXS 750	M59838161	M59838162	NW50	175 (6.9)	485 (19.1)	680 (26.8)	259 (10.2)	200 (7.9)	350 (13.8)

### Silencer Mounting Kits



Rear Exhaust (RE)	
GXS 160 / 250 & booster combinations	M58808151
GXS 450 / 750 & booster combinations	M59808151

Side Exhaust (SE)	
GXS 160 / 250 & booster combinations	M58808009
GXS 450 / 750 & booster combinations	M59838009

\* SE mounting kit raises pump to accommodate silencer.



## Inlet Spools

As every installation is different, a range of inlet spools are available for the GXS pumps. These are designed to mount our inlet valves and filters but also have instrumentation ports and the number of options ensure ease of connection to customers pipework.

## Specifications

- Painted carbon steel or stainless steel construction
- ½" BSP ports to connect GXS accessories or other ancillary devices
- Sizes available for complete range of GXS pumps and accessories

## Options

- Pressure gauge assembly
- Pressure transducer assembly (For PID control)
- Temperature transmitter assembly

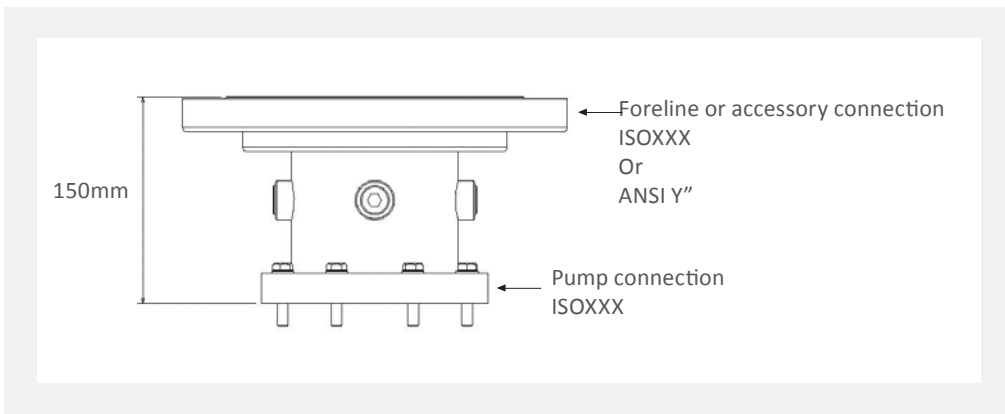

Description	Part Number		Mass / Kg	Pump Connection	Foreline / Accessory Connection	Height /mm	Accessory Ports
	Carbon Steel	Stainless Steel					
Inlet spool ISO63 - ANSI 4 inch	M58808002	M58808134	10	ISO63	4 inch ANSI	150	1 x 1 inch BSP female 3 x ¾ inch BSP female
Inlet spool ISO100 - ANSI 4 inch	M59808002	M59808134	12	ISO100	4 inch ANSI	150	1 x 1 inch BSP female 3 x ¾ inch BSP female
Inlet spool ISO100 - ANSI 6 inch	M58938002	M58938134	16	ISO100	6 inch ANSI	150	4 x ¾ inch BSP female
Inlet spool ISO160 - ANSI 6 inch	M58858002	M58828134	20	ISO160	6 inch ANSI	150	4 x ¾ inch BSP female
Inlet spool ISO160 - ANSI 8 inch	M59848002	M59848134	25	ISO160	8 inch ANSI	150	4 x ¾ inch BSP female
Inlet spool ISO163 - ISO100	M58808138	M58808135	9	ISO63	ISO100	150	1 x 1 inch BSP female 3 x ¾ inch BSP female
Inlet spool ISO100 - ISO100	M59808138	M59808135	10	ISO100	ISO100		1 x 1 inch BSP female 3 x ¾ inch BSP female
Inlet spool ISO100 - ISO160	M58828003	M58828135	13	ISO100	ISO160	150	4 x ¾ inch BSP female
Inlet spool ISO160 - ISO160	M58938003	M58938135	15	ISO160	ISO160	150	4 x ¾ inch BSP female
Inlet spool ISO160 - ISO200	M59848003	M59848135	19	ISO160	ISO160	150	4 x ¾ inch BSP female

# GXS ordering information

**G S 1 0 0 0 0 0**

## Application

G Industrial

## Pump Mechanism

S Screw

## Pumps/Boosters

- 2 160 (7.5 kW)
- 5 160 (7.5 kW) / 1750 (5.5 kW)
- 7 250 (7.5 kW)
- B 250 (7.5 kW) / 2600 (7.5 kW)
- D 450 (11 kW)
- F 450 (11 kW) / 2600 (7.5 kW)
- G 450 (11 kW) / 4200 (7.5 kW)
- L 750 (22 kW)
- N 750 (22 kW) / 2600 (7.5 kW)
- P 750 (22 kW) / 4200 (7.5 kW)

## Lubrication

1 PFPE (Drynert 25/6)

## Electrical

- 2 Low volt 200-230 V 3Ø 50/60 Hz
- 5 High volt 380-460 V 3Ø 50/60 Hz

## Installation

- 0 Side exhaust & skids
- 5 Rear exhaust & castors

## Pump Purges

- 0 Light Duty (SSP+HVP)
- 3 Medium Duty (SSP+HVP+Inlet+GB+Exh PM)
- 4 Medium Duty + High Flow Purge/Solvent Flush

SSP = Shaft seal purge,  
 HVP = High vacuum gearbox purge  
 Inlet = Inlet purge,  
 GB = Gas ballast,  
 Exh PM = Exhaust pressure monitor & purge  
 GXS450 & GXS750 Medium Duty (MD) variants require optional  
 PDT for operation  
 All pump variants configured for Medium Duty + High Flow Purge /  
 Solvent Flush (MD+) require optional PDT for operation

## Cooling

- 0 TMS Standard (GXS160 and GXS250)
- 2 TMS+ (GXS450 and GXS750)



# Complementary accessories

Control & Communication	
Pump Display Terminal (PDT)*	D37280700
Virtual Pump Display Terminal (VPDT)	D37488500
MCM MicroTIM	D37360320
Connector kit for MCM MicroTIM	D37422802
Profibus® Module	D39753000
Equipment support toolkit	D37217090

Instrumentation	
Water flow monitoring	A50783000
N2 Flow Switch	
Standard - Up to and including GXS450 LD	A50633000
High Flow - GXS450 MD pumps and higher	A50634000
Pressure Indicator Assembly	M58808141
Pressure Transducer Assembly (ASG)	M58808152
Temp Trans Assy	
Pump only	M58808160
Combinations	M58828160

Ancillary Equipment	
3/8" SS quick connector for water	A50721000
3/8" BSPF to 3/8" NPTM Brass Adaptor	U30011199
3/8" BSPM to 3/8" NPTM Brass Adaptor	U30011200
Connector plug 06 IL CM XLR	D37207061
Holster pump display module	D37209800
GXS Auxiliary gauge cable (0-10V)	D37241017
GXS Pressure input cable (4-20mA)	D37241019
GXS Pressure input connector (4-20mA)	D37241023
Drynert 25/6 fluid 1 kg (528 ml)	H11312021
Drynert 25/6 fluid 5 kg (2646 ml)	H11312025



## Service and Support

Your business success depends on maximum equipment uptime and minimum total cost of ownership, and we constantly strive to support those objectives. As a global leader in vacuum technology and processes, we understand how vacuum pumps and systems perform in real life. Our wide portfolio of services is designed with you in mind: to help keep your processes and equipment running in the most economical and environmentally efficient manner.

Services include:

- Overhaul and repair using genuine Edwards OEM parts
- OEM spares and kits available for immediate despatch
- ReManufactured products available for cost-effective expansion and backups
- Global network of expert field service engineers available to respond quickly to unexpected equipment failures
- Extended warranty, to help manage the cost of the unexpected

Our Expert Advantage Service Plans provide you with the on-going support necessary to continuously improve your operational efficiency and meet your business objectives. As service offerings may vary slightly from product to product, please contact your Edwards representative to discuss your specific requirements.

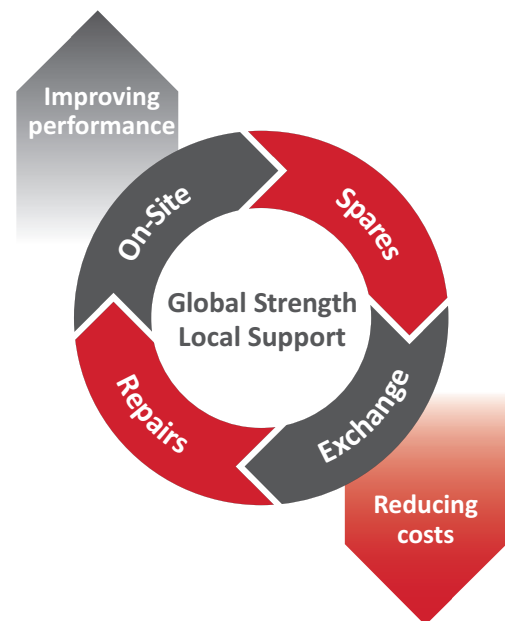



## GLOBAL CONTACTS

Publication Number: 3602 100 6 01  
 © Edwards Limited 2016. All rights reserved  
 Edwards and the Edwards logo are trademarks of  
 Edwards Limited

Whilst we make every effort to ensure that we  
 accurately describe our products and services,  
 we give no guarantee as to the accuracy or  
 completeness of any information provided in  
 this brochure.

Edwards Ltd, registered in England and Wales  
 No. 6124750, registered office: Innovation Drive,  
 Burgess Hill, West Sussex, RH15 9TW, UK.

### EMEA

<b>UK</b>	+44 1444 253 000 (local rate) 08459 212223
<b>Belgium</b>	+32 2 300 0730
<b>France</b>	+33 1 4121 1256
<b>Germany</b>	0800 000 1456
<b>Italy</b>	+ 39 02 48 4471
<b>Israel</b>	+ 972 8 681 0633

### ASIA PACIFIC

<b>China</b>	+86 400 111 9618
<b>India</b>	+91 20 4075 2222
<b>Japan</b>	+81 47 458 8836
<b>Korea</b>	+82 31 716 7070
<b>Singapore</b>	+65 6546 8408
<b>Taiwan</b>	+886 3758 1000

### AMERICAS

<b>USA</b>	+1 800 848 9800
<b>Brazil</b>	+55 11 3952 5000