

nES SERIES SINGLE STAGE ROTARY VANE PUMPS

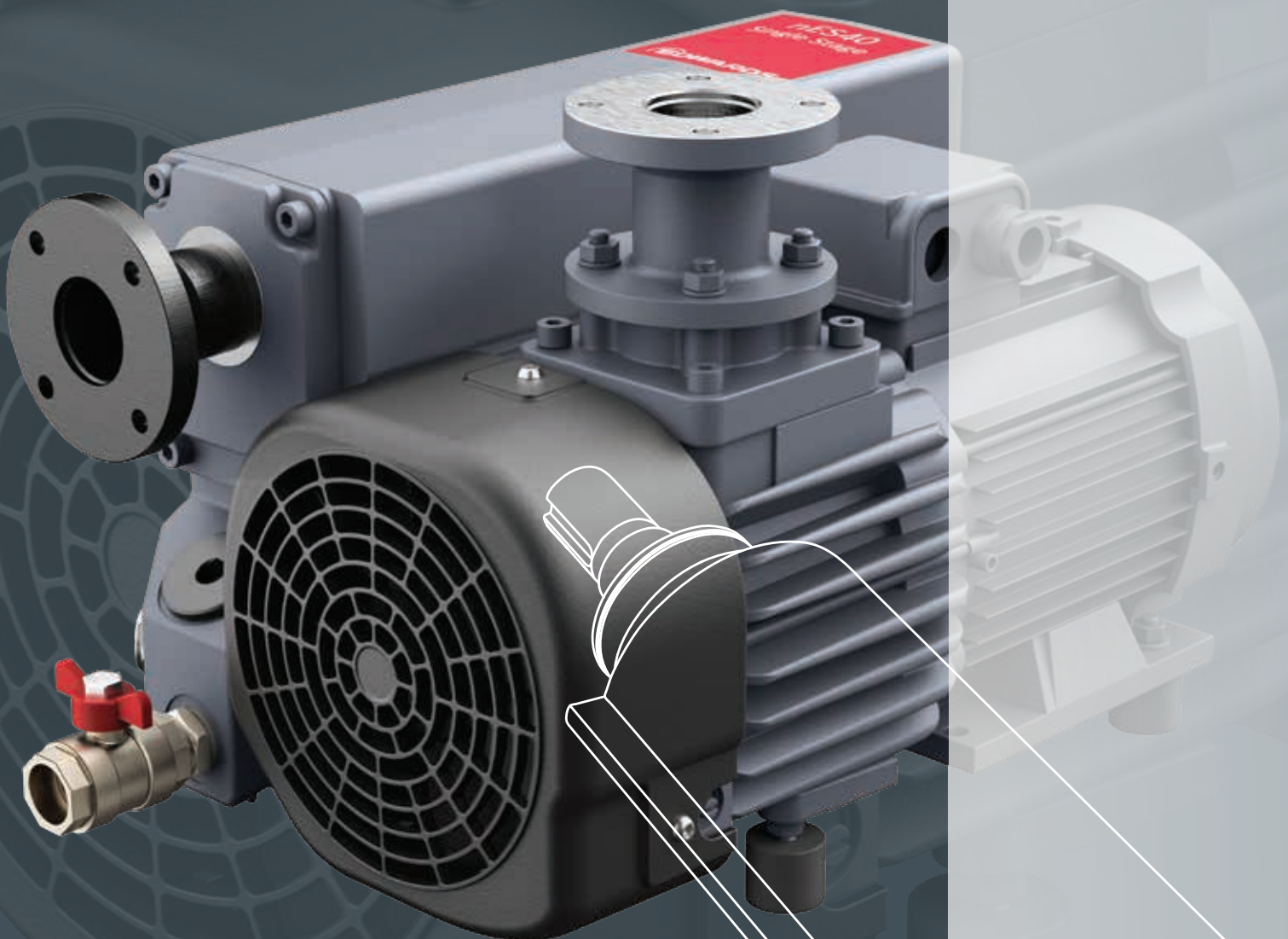



EDWARDS THE PARTNER OF CHOICE

Edwards is a world leader in the design, technology and manufacture of vacuum pumps for industrial applications with over 99 years' history.

We believe in delivering results that bring value to our customers by using our breadth of industry experience to identify and apply solutions. Using the most innovative and up-to-date modelling techniques, we can optimise the pumping configuration for customers to provide a system design giving the maximum performance in the most reliable and cost-effective way.

nES SERIES

NEXT GENERATION SINGLE STAGE ROTARY VANE PUMPS

The Edwards nES single stage series represents the next advancement in oil sealed rotary vane vacuum pumps for use in a wide of range industries and applications.

Offering high reliability, low life cycle cost and proven performance, the nES series provides an ideal solution to suit a broad range of requirements.

FEATURES

Proven performance

The Edwards nES series delivers consistent pumping performance with excellent vacuum stability. High pumping speed at low pressures with good condensable vapour handling capability provides an ideal solution for a range of applications.



High reliability

The pump mechanism provides high reliability ensuring maximum productivity. Engineered with high quality components, an effective oil return system and integrated mist filter, the nES series is designed to maximise process efficiency.



Low lifecycle cost

Efficient cooled motors, optimised oil retention, low pump temperatures, high reliability and minimum maintenance provides excellent lifecycle cost compared to other single stage rotary vane pumps.



Compact and clean

The nES series is both robust and compact in design. In addition, low noise and vibration minimises environmental impact.

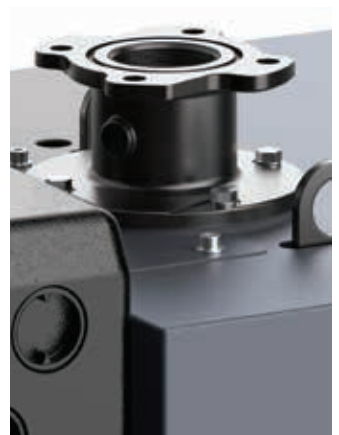
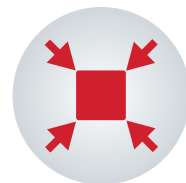

nES PUMP TECHNOLOGY

PUMP MECHANISM

The pump mechanism is designed to provide optimum pumping performance without fluctuation in vacuum levels.

EFFICIENT COOLING

The efficient cooling system enables low operating temperatures and increased oil life improving reliability.

OIL RETURN SYSTEM

The optimised oil return and separation system supports stable pumping performance and minimises oil loss. Use of Edwards Ultragrade Performance 70 oil enables optimum pumping performance, and effective time between service.

GAS BALLAST FACILITY

The gas ballast mechanism facilitates effective pumping and management of condensable vapours.

DRIVE TECHNOLOGY

Motors are highly efficient meeting latest efficiency standard and are in accordance with UL and European standards.

INSTALLATION FLEXIBILITY

Pumps are compatible with both ISO and G connections, providing flexibility in installation.



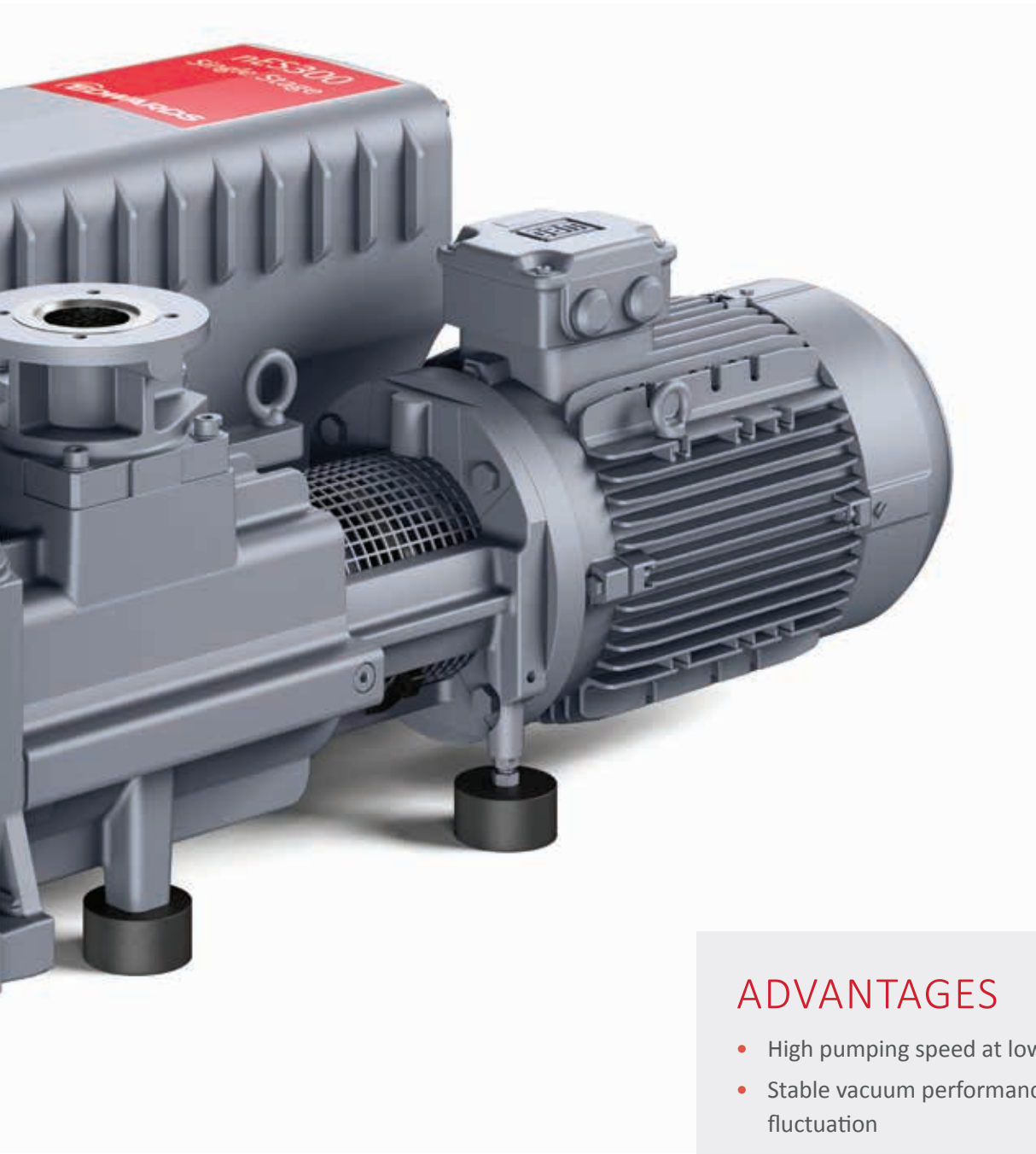

ADVANTAGES

- High pumping speed at low pressure
- Stable vacuum performance with no pressure fluctuation
- Good condensable vapour handling capability with gas ballast
- Optimised oil return system and integrated exhaust mist filter
- Low noise and vibration
- Efficient cooled motor
- High reliability through proven technology
- Compact design
- Low and easy maintenance - therefore high productivity



TECHNICAL DATA

	Units	nES40	nES65	nES100	nES200	nES300
Maximum Displacement 50Hz	m ³ h ⁻¹ / cfm	44.0/25.9	59.0/34.8	98.0/57.4	180/106	280/165
Maximum Displacement 60Hz	m ³ h ⁻¹ / cfm	53.0/31.2	71.0/41.8	117/68.9	230/130	340/200
Pumping Speed (50 Hz)	m ³ h ⁻¹ / cfm	38.5/22.7	54.0/31.8	87.5/51.5	170/100	240/141
Pumping Speed (60 Hz)	m ³ h ⁻¹ / cfm	47.0/27.7	64.0/37.7	105/61.8	200/118	290/171
Ultimate vacuum without gas ballast	mbar / torr	0.5/0.4	0.5/0.4	0.5/0.4	0.08/0.06	0.08/0.06
Ultimate vacuum with gas ballast	mbar / torr	1.5/1.1	1.5/1.1	1.5/1.1	0.7/0.5	0.7/0.5
Inlet Connection	ISO / G	ISO40 / G1 ¼	ISO40 / G1 ¼	ISO40 / G1 ¼	ISO63 / G2	ISO63 / G2
Outlet Connection	ISO / G	ISO40 / G1 ¼	ISO40 / G1 ¼	ISO40 / G1 ¼	ISO63 / G2	ISO63 / G2
Max permitted outlet pressure	bar gauge	1.15 abs	1.15 abs	1.15 abs	1.15 abs	1.15 abs
Max water vapour pumping rate (50Hz)	kg h ⁻¹ / lb h ⁻¹	0.76/0.80	1.0/1.1	1.60/1.69	3.4/3.6	1.3/1.4
Max water vapour pumping rate (60Hz)	kg h ⁻¹ / lb h ⁻¹	0.90/0.95	1.25/1.32	1.70/1.80	5.4/5/7	1.8/1.9
Dimensions (L, W, H) Approximate (tbc)	mm	623/332/296	706/367/312	762/434/317	1100/535/415	1143/573/450
Weight Approximate (tbc)	kg / lb	67/148	86/190	104/230	142/313	244/539
Motor protection rating		IP55	IP55	IP55	IP55	IP55
Motor power (50Hz)	kW / hp	1.5/2.0	2.2/3.0	3.0/5.0	5.5/8	7.5/10
Motor power (60Hz)	kW / hp	1.8/3.0	2.6/4/0	3.6/6.0	6.6/10	9/13
Noise level (50 Hz)	dB(A)	58	60	61	69	72
Noise level (60 Hz)	dB(A)	60	64	64	73	76
Oil refill capacity	litre	1	2	2	5-9	8.5-11.5
Recommended oil	Edwards ULTRAGRADE Performance 70					

DIMENSIONS

nES40

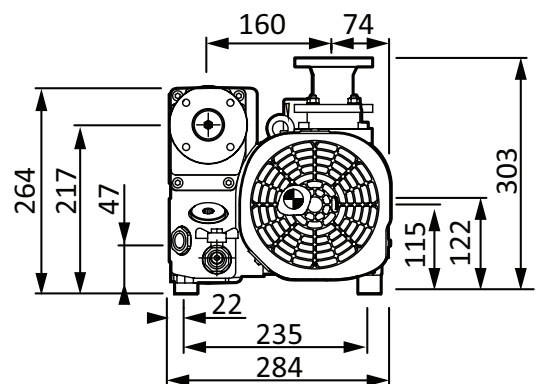
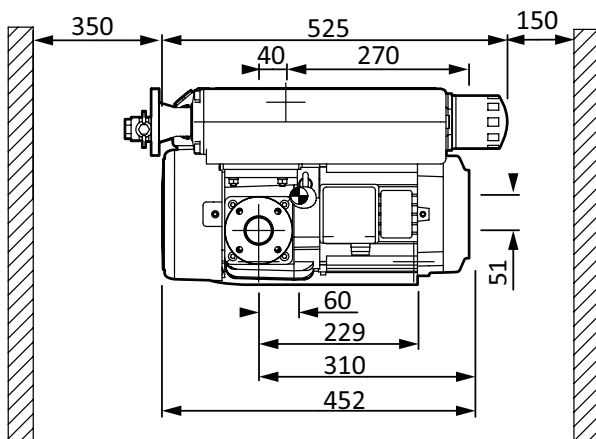

	Units	nES470	nES570	nES630	nES750
Maximum Displacement 50Hz	m ³ h ⁻¹ / cfm	470/277	570/366	700/412	840/494
Maximum Displacement 60Hz	m ³ h ⁻¹ / cfm	570/366	-	840/494	-
Pumping Speed (50 Hz)	m ³ h ⁻¹ / cfm	400/236	470/277	640/377	755/444
Pumping Speed (60 Hz)	m ³ h ⁻¹ / cfm	470/277	-	755/444	-
Ultimate vacuum without gas ballast	mbar / torr	0.08/0.06	0.08/0.06	0.08/0.06	0.08/0.06
Ultimate vacuum with gas ballast	mbar / torr	0.7/0.5	0.7/0.5	0.7/0.5	0.7/0.5
Inlet Connection	ISO-F / G	ISO100 / G3	ISO100 / G3	ISO100	ISO100
Outlet Connection	ISO-F / G	ISO100 / G3	ISO100 / G3	ISO100	ISO100
Max permitted outlet pressure	bar gauge	1.15 abs	1.15 abs	1.15 abs	1.15 abs
Max water vapour pumping rate (50Hz)	kg ^h ⁻¹ / lbh ⁻¹	5.0/5.3	7.5/8.0	17/18	24/25
Max water vapour pumping rate (60Hz)	kg ^h ⁻¹ / lbh ⁻¹	7.5/8.0	-	24/25	-
Dimensions (L, W, H) Approximate (tbc)	mm	1305/863/733	1305/863/733	1566/989/740	1566/989/740
Weight Approximate (tbc)	kg / lb	480/1059	550/1214	760/1678	760/1678
Motor protection rating		IP55	IP55	IP55	IP55
Motor power (50Hz)	kW / hp	11/15	11/15	18.5/26	18.5/26
Motor power (60Hz)	kW / hp	13.2/18	-	21/30	-
Noise level (50 Hz)	dB(A)	72	75	72	75
Noise level (60 Hz)	dB(A)	75	-	75	-
Oil refill capacity	litre	20	20	20-23	20-23
Recommended oil		Edwards ULTRAGRADE Performance 70			

nES65

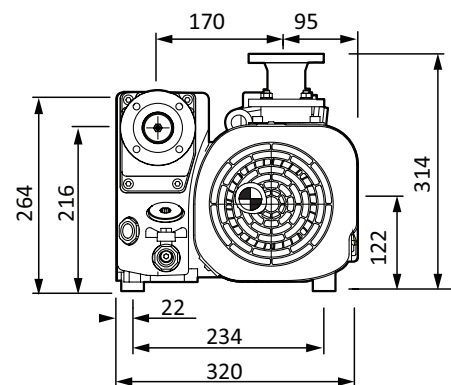
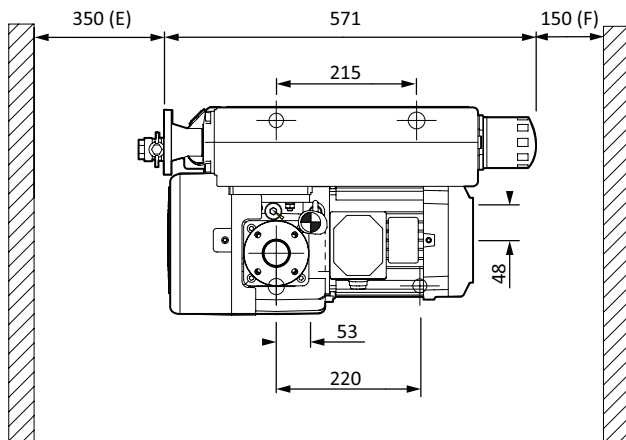

DIMENSIONS

nES100

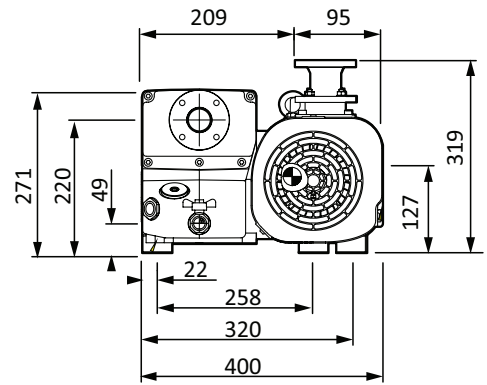
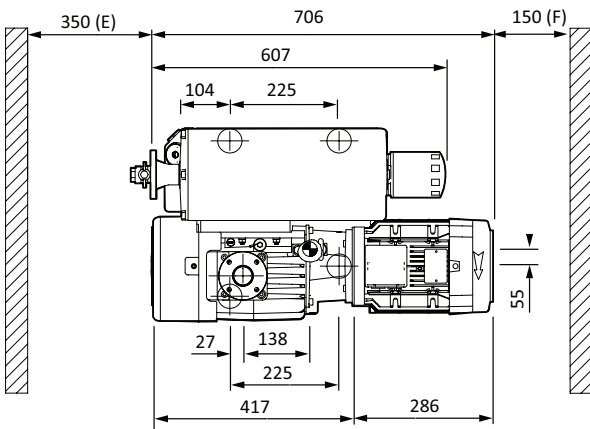

nES200

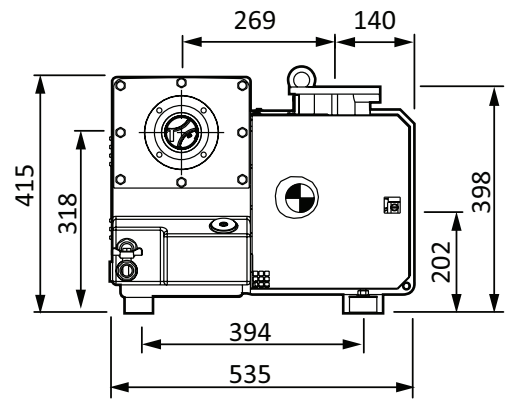
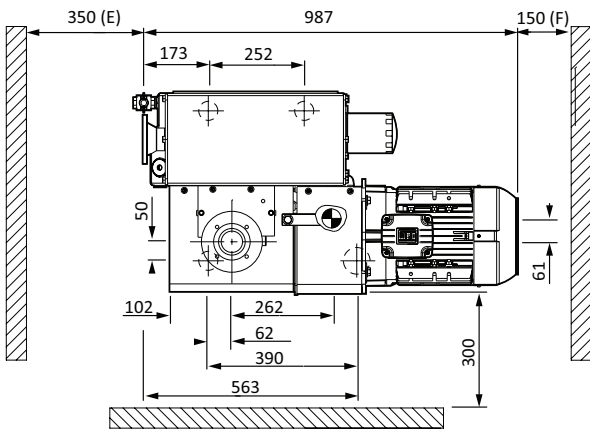

nES300

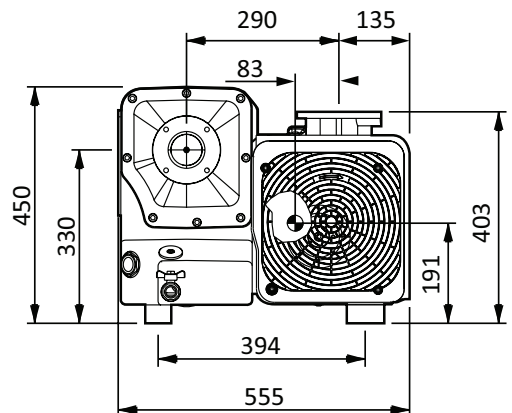
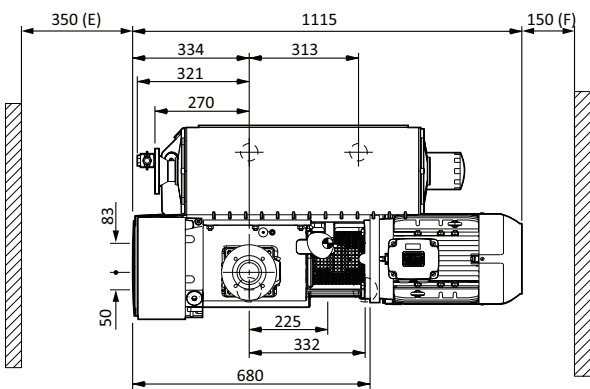

nES470 / nES570

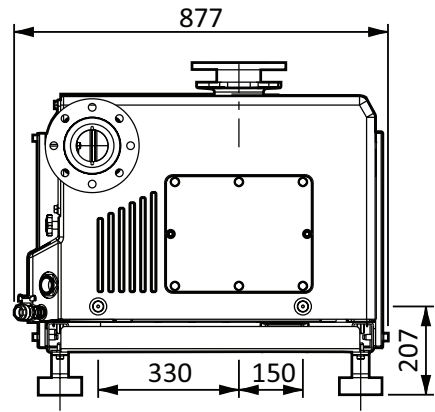
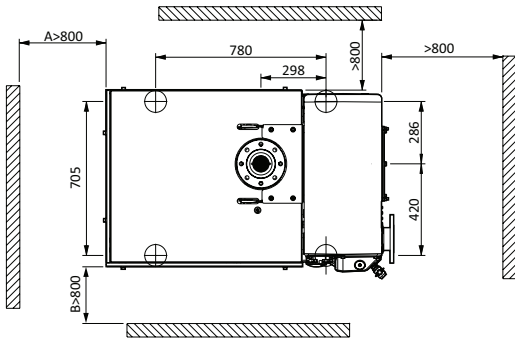

nES630 / nES750

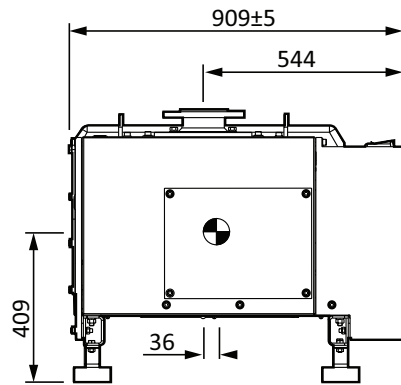
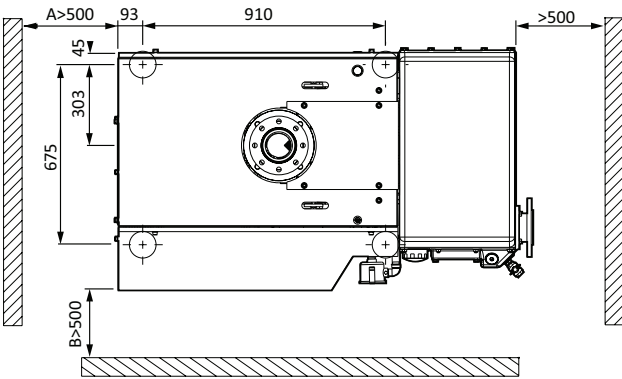

PERFORMANCE CURVES

nES40

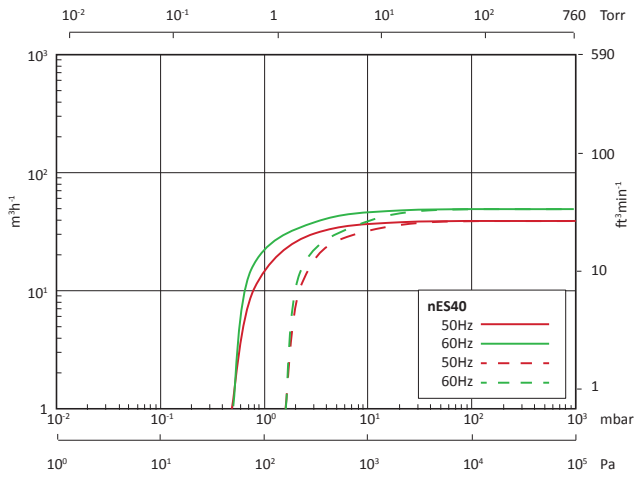

nES65

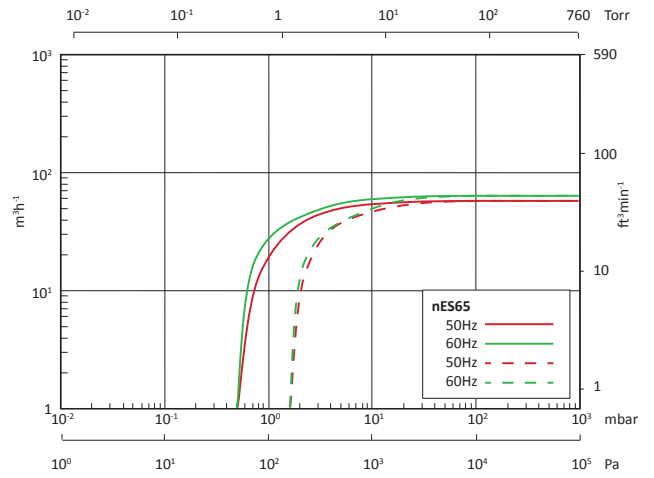

nES100

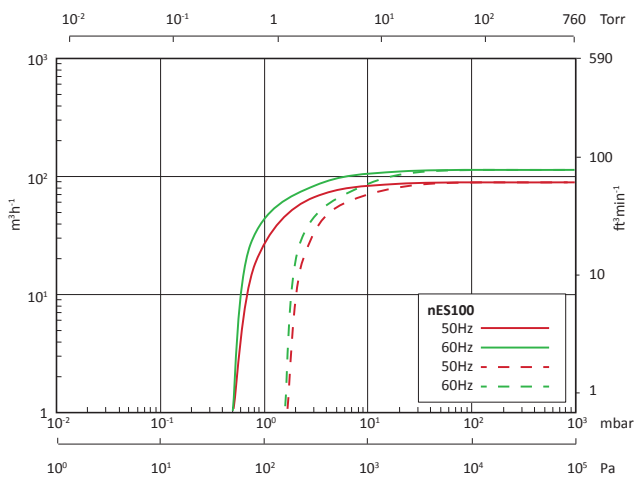

nES200

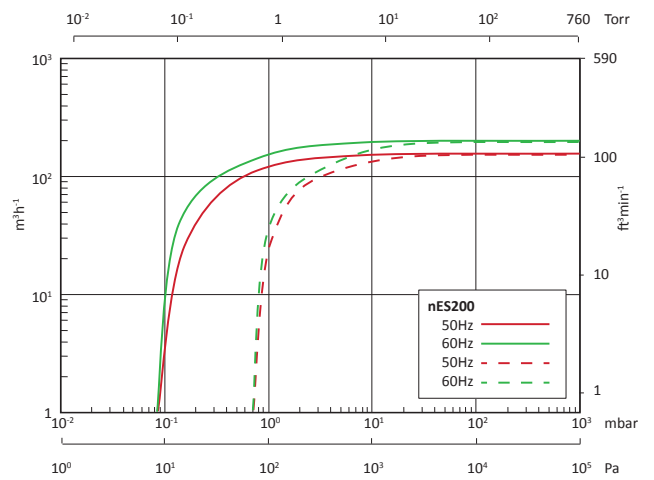

nES300

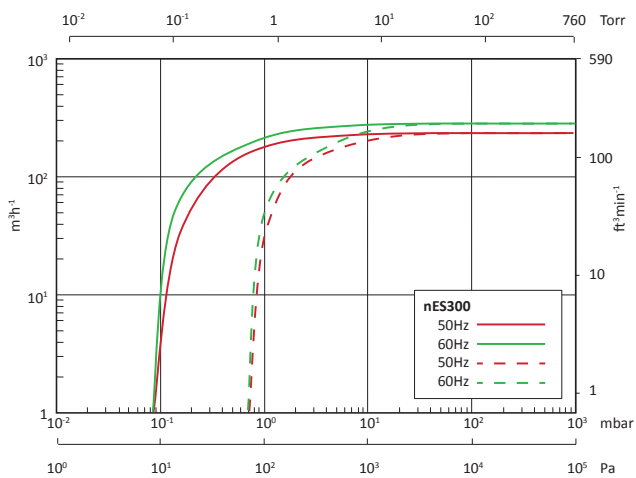

nES470

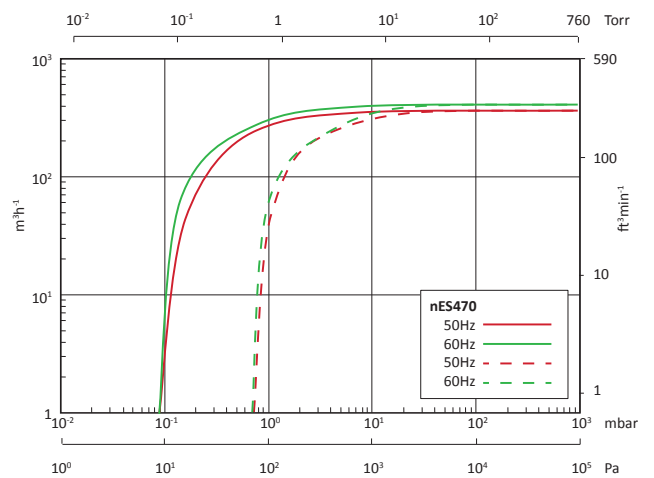

nES570

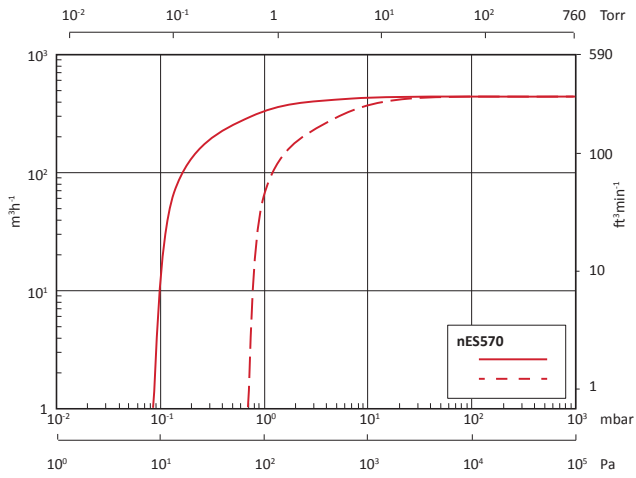

nES630

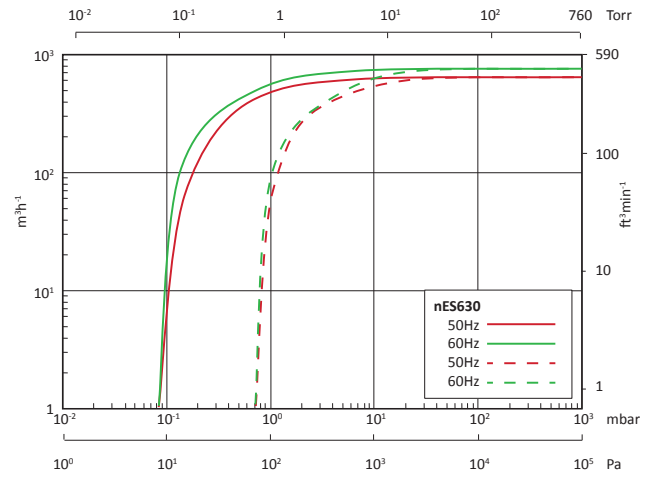

nES750

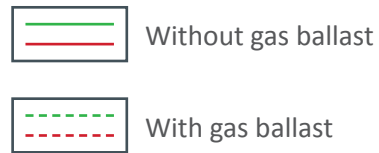
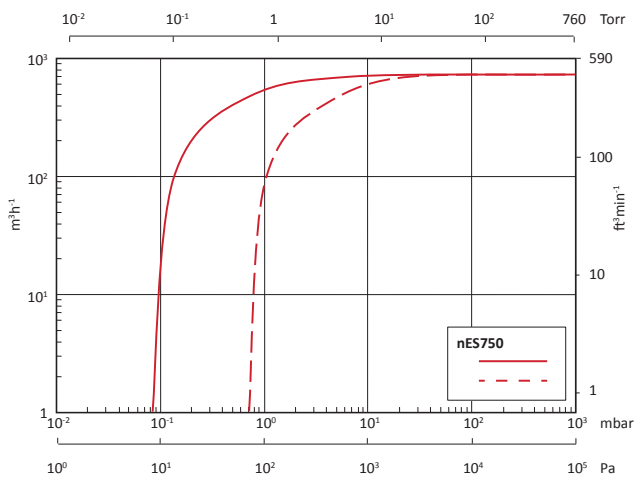

APPLICATIONS

nES series single stage pumps offer an ideal combination of vacuum performance and stability with convenience and investment affordability in a wide range of Industrial applications.

Coating

- Load locks of glass coater and large in line coaters
- Web and roll coating
- Optical, ophthalmic and display coating
- Surface coating like plasma deposition and reflective or decorative

Heat treatment

- Tempering
- Quenching
- Annealing
- Vacuum brazing
- E-beam and plasma welding

Drying

- Transformer drying
- Automotive drying and filling systems
- Refrigeration and air conditioning
- Battery and capacitor drying

General industrial

- Sterilisation
- Plasma cleaning/sterilising
- Oil/resin degassing
- Food processing
- Leak detection
- Cryo interspace evacuation
- Vacuum insulated panels
- Vacuum insulated glass
- Cylinder filling



nES PUMP AND BOOSTER COMBINATIONS

Edwards is able to offer a range of nES rotary vane pumps and mechanical boosters, complete with combination kits to mount the mechanical booster. The fitting of a mechanical booster to an nES rotary vane pump significantly increases the pumping speed and vacuum performance of your system, as well as increasing the ultimate vacuum attainable.

Edwards is able to assist in the selection of the combination most suited to your requirement.

EH range

The EH range of mechanical boosters (250-4200 m³h⁻¹, 150-2500 cfm), with their unique hydrokinetic drive allowing continuous operation from atmosphere to ultimate vacuum, cuts pump down times by up to 50%.

Systemisation

Our comprehensive range of nES pumps and EH mechanical boosters, complete with combination kits allows the user to specify a complete system. Specifying a combination is simply a process of selecting the nES pump and the required mechanical booster which would enable us to build a complete systemised unit ready to use.

Depending on the type of nES and booster pump combination the assembled unit will either be a Frame Mount or a Direct Mount unit. Alternatively, combination kits are available to allow the nES pump and EH mechanical booster, to be assembled at the customers site.

Please contact Edwards for additional information.

nES40



nES65



nES100



nES200



nES300



nES470



nES570



nES630



nES750



ORDERING INFORMATION

Model	Motor rating	Voltage	Cooling	Part Number
nES40	Wide range	220 - 230 V & 380 - 400 V +-10 %; 50 Hz 220 - 230 V & 380 - 400 V & 440 - 460 V +-10 %; 60 Hz	Air	A35104940
	Japan	200 V -15 % + 10 %; 50 & 60 Hz	Air	A35104934
nES65	Wide range	220 - 230 V & 380 - 400 V +-10 %; 50 Hz 220 - 230 V & 380 - 400 V & 440 - 460 V +-10 %; 60 Hz	Air	A35304940
	Japan	200 V -15 % + 10 %; 50 & 60 Hz	Air	A35304934
nES100	Wide range	220 - 240 V & 380 - 415 V +-10 %; 50 Hz 220 - 230 V & 380 - 400 V & 460 V +-10 %; 60 Hz	Air	A35404940
	Japan	200 V -15 % + 10 %; 50 & 60 Hz	Air	A35404934
nES200	Wide range (incl. JP)	200 - 240 V & 380 - 415 V +-10 %; 50 Hz 200 - 230 V & 380 - 400 V & 440 - 460 V +-10 %; 60 Hz	Air	A35504950
nES300	Wide range (incl. JP)	200 - 240 V & 380 - 415 V +-10 %; 50 Hz 200 - 230 V & 380 - 400 V & 460 V +-10 %; 60 Hz	Air	A35604950
nES470	Wide range (incl. JP)	200 - 240 V & 380 - 415 V +-10 %; 50 Hz 200 - 230 V & 380 - 400 V & 460 V +-10 %; 60 Hz	Air	A35704950
	Wide range (incl. JP)	200 - 240 V & 380 - 415 V +-10 %; 50 Hz 200 - 230 V & 380 - 400 V & 460 V +-10 %; 60 Hz	Water	A35705950
nES570	Wide range (incl. JP) 50 Hz only	200 - 240 V & 380 - 415 V +-10 %; 50 Hz only	Air	A35804954
	Wide range (incl. JP) 50 Hz only	200 - 240 V & 380 - 415 V +-10 %; 50 Hz only	Water	A35805954
nES630	Wide range (incl. JP)	200 - 240 V & 380 - 415 V +-10 %; 50 Hz 200 - 230 V & 380 - 400 V & 460 V +-10 %; 60 Hz	Air	A35904950
	Wide range (incl. JP)	200 - 240 V & 380 - 415 V +-10 %; 50 Hz 200 - 230 V & 380 - 400 V & 460 V +-10 %; 60 Hz	Water	A35905950
nES750	Wide range (incl. JP) 50 Hz only	200 - 240 V & 380 - 415 V +-10 %; 50 Hz only	Air	A36904954
	Wide range (incl. JP) 50 Hz only	200 - 240 V & 380 - 415 V +-10 %; 50 Hz only	Water	A36905954

SERVICE AND SUPPORT

Keeping nES pump working at the top level is paramount, Edwards offers a **wide range of maintenance service plans**, tailored to the Customer's needs. From **Field Service intervention** to **Managed Maintenance contracts**, Edwards will take care of the vacuum pump to ensure **best performance** and **longevity of the product** for an optimum total cost of ownership. Further than genuine spare parts, kits and oil, we can provide the following fast and effective service solutions for nES series pumps:

- Edwards highly trained Service Technicians can carry out **commissioning, health check, routine maintenance, troubleshooting and repair for vacuum equipment**, anywhere in the world. We invest in the tools, training and inventory that enable our team of service engineers to deliver quality service in a safe and consistent manner, according to manufacturing recommendations, using genuine Edwards' spare parts and oils.
- **Managed Maintenance contracts**, Edwards will take over maintenance planning and responsibility for servicing your nES pumps. Regular scheduled maintenance can identify potential problems before they occur and plans can be structured around different levels of care. Managed maintenance also enables cost management and will help the Customer to avoid the risk and expense associated with unplanned downtime.
- **Pump overhaul service** in our Edwards' Service Technology Centres located around the world. No matter the condition of your nES pump our highly trained specialists can handle it, even if coming from harsh environments or critical applications.





GLOBAL CONTACTS

Publication Number: 3602 009 8 01
 © Edwards Limited 2018. All rights reserved
 Edwards and the Edwards logo are trademarks of
 Edwards Limited

Whilst we make every effort to ensure that we
 accurately describe our products and services,
 we give no guarantee as to the accuracy or
 completeness of any information provided in
 this brochure.

Edwards Ltd, registered in England and Wales
 No. 6124750, registered office: Innovation Drive,
 Burgess Hill, West Sussex, RH15 9TW, UK.

EMEA

UK	+44 1444 253 000 (local rate) 08459 212223
Belgium	+32 2 300 0730
France	+33 1 4121 1256
Germany	0800 000 1456
Italy	+ 39 02 48 4471
Israel	+ 972 8 681 0633

ASIA PACIFIC

China	+86 400 111 9618
India	+91 20 4075 2222
Japan	+81 47 458 8836
Korea	+82 31 716 7070
Singapore	+65 6546 8408
Taiwan	+886 3758 1000

AMERICAS

USA	+1 800 848 9800
Brazil	+55 11 3952 5000